

# Eclipse ImmersoPak

---

## Burners

Model IP010

Version 2

Parameter	Modulating Air		
	Nat Gas	Propane	Butane
High Fire kBtu/hr. (kW) @ 3% O <sub>2</sub>	3200 (938)	3050 (894)	3000 (879)
Low Fire kBtu/Hr. (kW)	200 (58.6)	200 (58.6)	200 (58.6)
High Fire CO (ppm) @ 3% O <sub>2</sub>	<10	<10	<10
Orifice Size (mm)	30	25	22.5
Air Pressure "w.c. (mbar) @ Max. Input – Air Pressure at burner inlet (Tap "A")	3.4 (8.5)		
Main Gas Pressure "w.c. (mbar)	Maximum	138.5 (345)	
	Minimum	15 (37)	
	Recommended	18 (45)	
Weight – less actuator lbs. (kg)	164 (74.4)		
Blower Type	10" Packaged		
Gas Piping	N.P.T. or B.S.P.		
Flame Detection	U.V. Scanner		

- All information is based on laboratory testing with a 12" diameter tube effective length of 50 feet. Different tube sizes and conditions (including backpressure) may affect the data.
- All information is based on standard tube design. Changes in the tube will alter performance and pressures.
- All inputs based upon gross calorific values.
- Plumbing of air and gas will affect accuracy of orifice readings. All information is based on generally acceptable air and gas piping practices.
- For 65% to 80% efficiency at high fire, tube length should be 30 to 75 feet long.
- Eclipse reserves the right to change the construction and/or configuration of our products at any time without being obliged to adjust earlier supplies accordingly.

## Performance Graphs

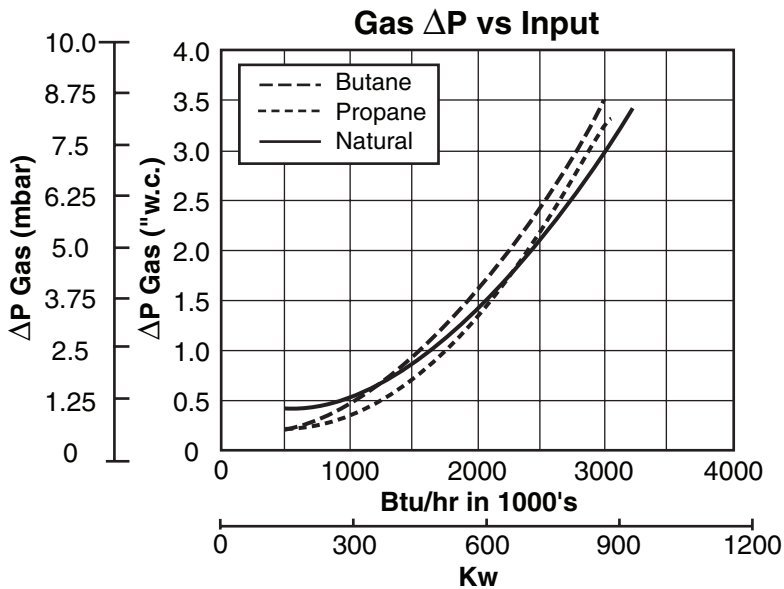
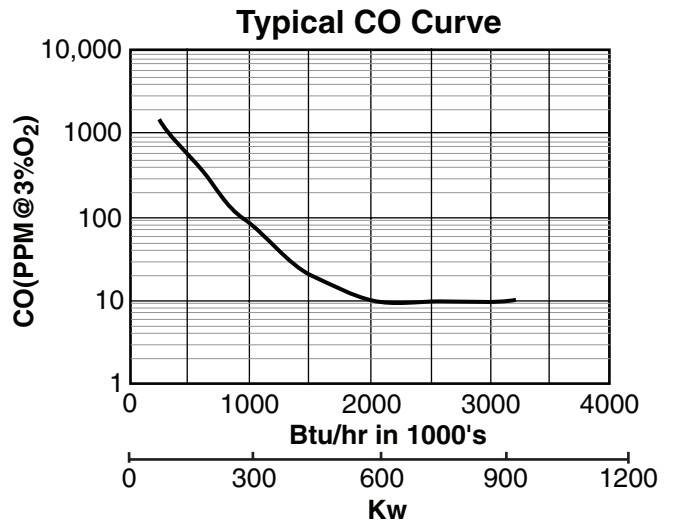
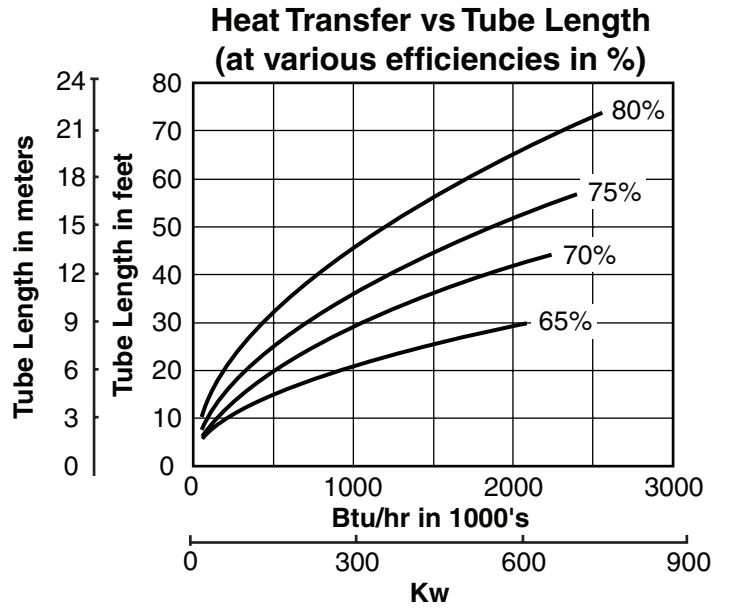
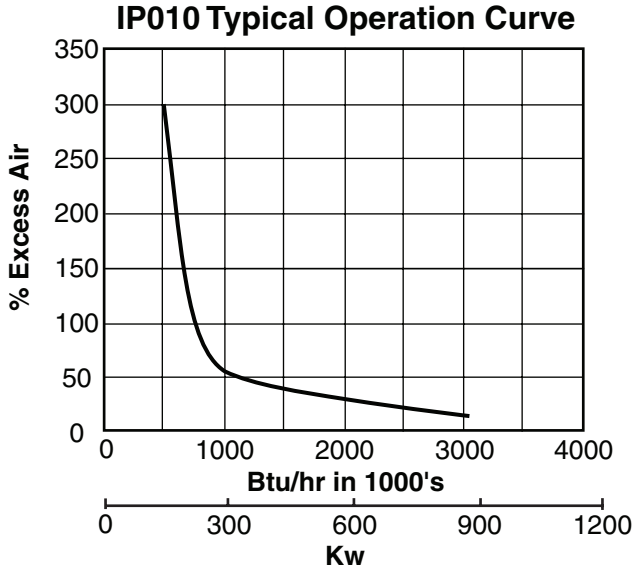

# Dimensions & Specifications

## Dimensions in mm (inches)

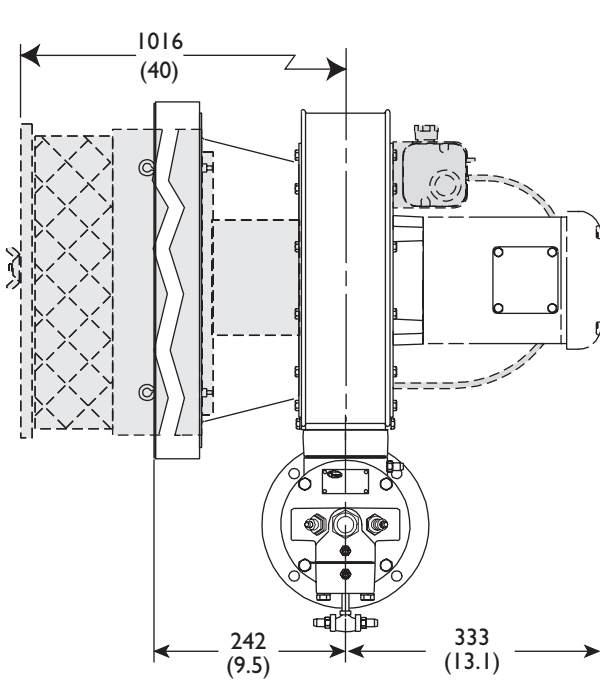

*Optional Filter/Silencer and Pressure Switch shown in gray.*

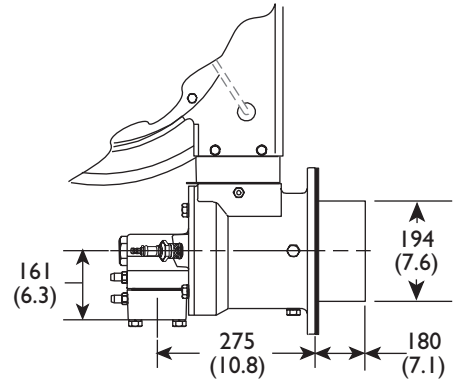
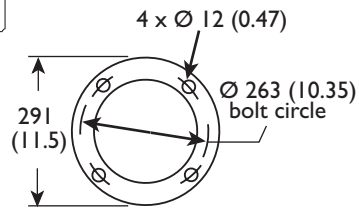
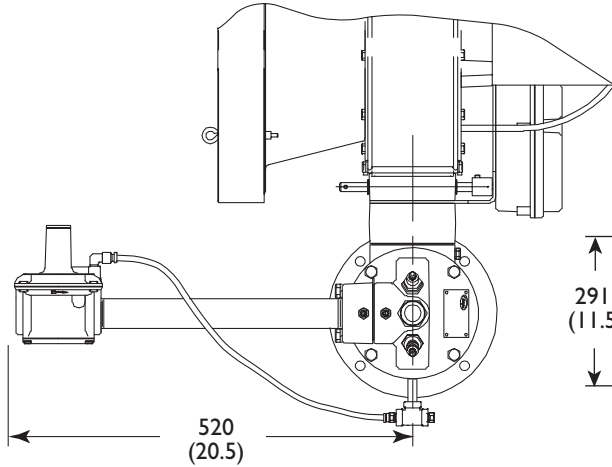
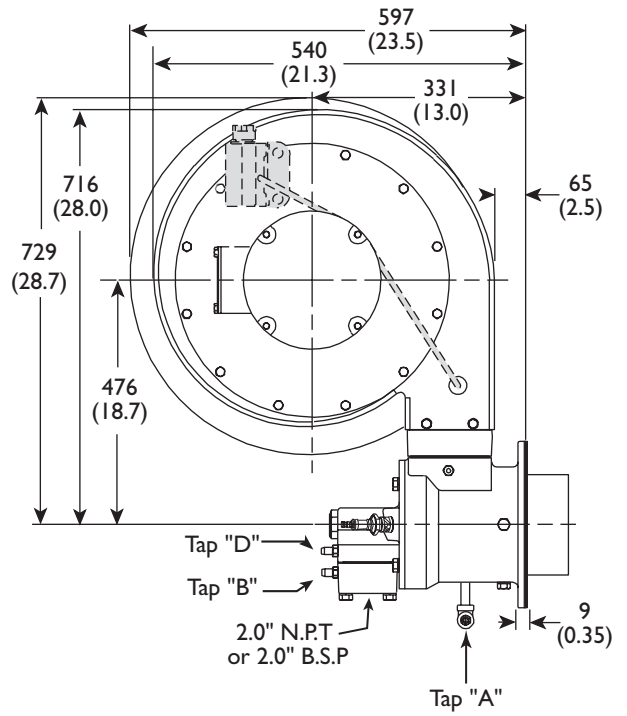

### Orientation

#### Upright

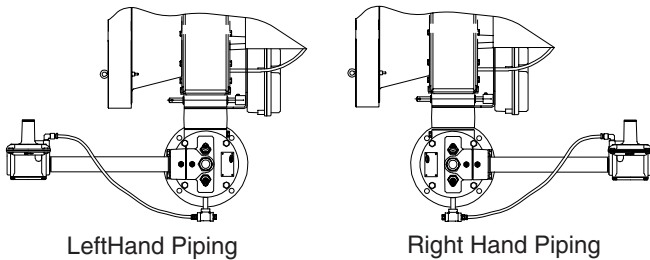

#### Inverted

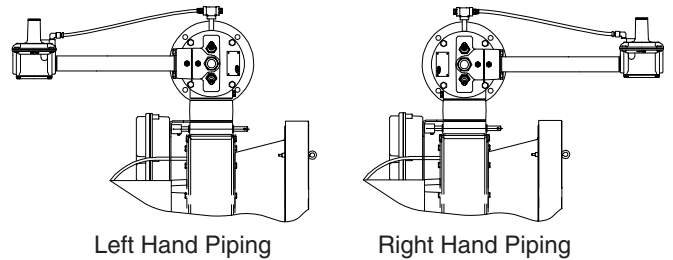



**Offered By:**

Power Equipment Company  
2011 Williamsburg Road  
Richmond, Virginia 23231  
Phone (804) 236-3800  
Fax (804) 236-3882

---

[www.peconet.com](http://www.peconet.com)